

Vacuum Pigtailed Fiber Optic Feedthrough

Hermetic Fiber Optic Feedthrough with Pigtail Interface



Operating temperatures*	Standard -25°C/85°C High Temp. -40°C/180°C
Hermeticity	10 ⁻¹⁰ to 10 ⁻¹² mbar.l/s
Fiber type**	SM, MM or PM
Fiber protection	Stainless steel flexible tubing (Ø 3mm) perforated PTFE (Ø 900um) ; Customized
Flange type	CF16 - CF160, KF16 - KF50, ISO or customized
Flange material	Stainless steel (304L and 316L) and others
Connector (stainless steel)	FC/PC, FC/APC, SMA 905, ST/PC

*Depends on type of fiber

**Various operational wavelengths on request

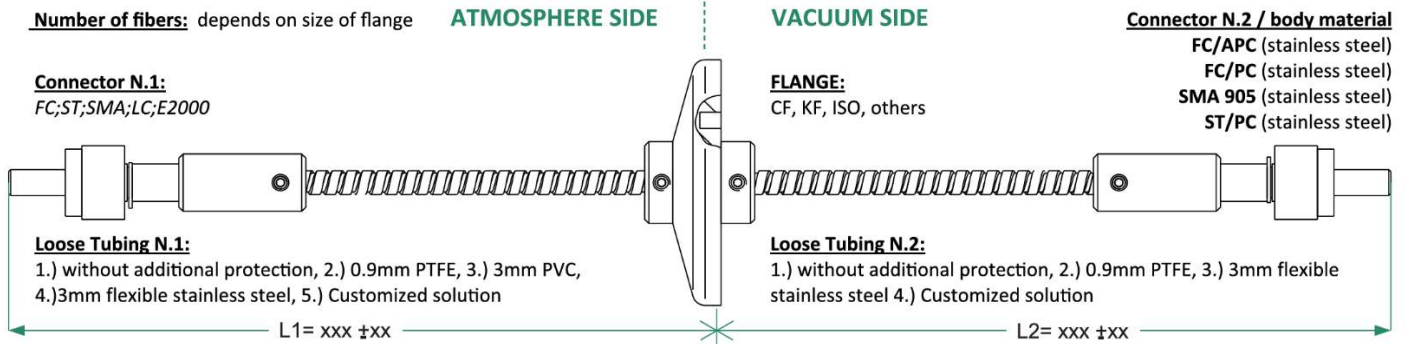

Optical fiber feedthroughs for vacuum applications. Vacuum fiber feedthroughs are suitable for use in various areas of research and development, and in many industrial applications.

Vacuum fiber feedthroughs are manufactured according to specific customer requirements. Optical fibers can be sealed in standard or atypical flanges for various areas of feedthrough applications.

Several variants of Pigtailed Feedthroughs (many other configurations are possible):

<p>KF 16; 2CH SMA 905; 3mm/PTFE</p>	<p>CF16; 2xCH SM FC/APC; 3mm/3mm</p>	<p>CF16; 2xCH SM FC/APC; 3mm/3mm</p>
<p>KF40 STUB; 8CH FC/APC; PTFE/PTFE</p>	<p>CF40; 4CH PM FC/APC 3mm/3mm</p>	<p>CF63; 45CH Bare Fiber</p>

Among other things we offer: Adapter Feedthrough, Pressure Feedthrough, Vacuum Compatible Cables, etc..

1CH - KF16 - SMA905 - HV

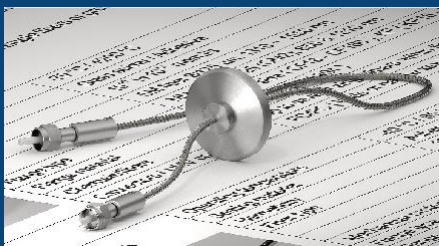

4CH - KF16 - SMA905 - HV



4CH - CF16 - SMA905 - UHV

