



2000W
Powerful
14.5 W/In.³
Small
2.1kg
Light

As a new generation of industrial-grade programmable power supply, AZ2000 series has digital design, which makes it have ultra-high programmable accuracy, Comprehensive parameter monitoring, multi-functional analog and digital interfaces, making your power system design more accurate and efficient.

The AZ2000 series is designed to comply with IEC/EN62368-1, IEC6061-1, EN55032 and relevant international standards

It empowers high-end industries and medical equipment continuously.

FEATURES:

• Programmable output Voltage (0% ~ 107.5%)

• Programmable output Current (0% ~ 107.5%)

• Analog and digital interface control

• I²C, Modbus, CAN bus communication protocol Selectable

• Constant current function

• Built-in OR-ing FETs

• Selectable 5V, 2A or 12V, 0.83A auxiliary output

• Intelligent GUI to set and monitoring parameter

MODEL	AZ2000-12	AZ2000-15	AZ2000-24	AZ2000-30	AZ2000-36	AZ2000-48	AZ2000-60
DC Voltage Rated	12V	15V	24V	30V	36V	48V	60V
Rated Current	166.67A	133.34A	83.34A	66.67A	55.56A	41.67A	33.34A
Rated Power	2000W						
Ripple & Noise(Max.)	150mVp-p	180mVp-p	180mVp-p	180mVp-p	180mVp-p	180mVp-p	240mVp-p
Efficiency(Typ.)	89.0%	90.0%	91.0%	92.0%	92.0%	93.0%	93.0%

Note

1.All parameters NOT specially mentioned are measured at 230VAC input, full load, 25°C of ambient temperature.
2.De-rating may apply in low input voltage. Please check the de-rating curve for more details.

MODEL	AZ2000-12	AZ2000-15	AZ2000-24	AZ2000-30	AZ2000-36	AZ2000-48	AZ2000-60	
Output Specifications								
DC Voltage Rated	V	12	15	24	30	36	48	60
DC Current Rated	A	166.67	133.34	83.34	66.67	55.56	41.67	33.34
Programming And Readback (I²C,RS485,CAN)								
Vout programming accuracy	--	0.3% of Vset +0.2% of rated output Voltage						
Iout programming accuracy	--	0.3% of Iset +0.2% of rated output current						
Vout programming resolution (Note.1)	--	3mV						
Iout programming resolution	--	3mA						
Vout readback accuracy	--	0.3% of actual +0.2% of rated output Voltage						
Iout readback accuracy (Note.1)	--	0.3% of actual +0.2% of rated output current						
Vout readback resolution	--	1mV						
Iout readback resolution	--	1mA						
Analog Programming And Monitoring (0~5V/0~5KΩ)								
Vout voltage programming	--	0~107.5%, 0~5V,Accuracy and linearity: ±0.5% of rated Vout.						
Iout voltage programming (Note.1)	--	0~107.5%, 0~5V ,Accuracy and linearity: ±1% of rated Iout.						
Vout resistor programming	--	0~107.5%, 0~5Kohm . Accuracy and nonlinearity: ±1% of rated Vout.						
Iout resistor programming	--	0~107.5%, 0~5Kohm .Accuracy and nonlinearity: ±1% of rated Iout.						
Output current monitor	--	0~3.3V user selectable. Accuracy: ±1%.						
Output voltage monitor	--	0~3.3V user selectable. Accuracy: ±1%.						
Constant Voltage Mode								
DC Voltage Rated	V	12	15	24	30	36	48	60
Programming Voltage Range	V	0~12.9	0~16.125	0~25.8	0~32.25	0~38.7	0~51.6	0~64.5
Ripple & Noise(P-P),Full load	mVp-p	150	180	180	180	180	180	240
Line Regulation (Note.2) ,Full load	--	±0.2%						
Load Regulation (Note.3)	--	±0.5%						
Remote sense compensation/wire	V	Max 2.5% of rate Vout						
Hold-up time,Full load, 100%~90%	--	16ms						
Constant Current Mode								
DC Current Rated	A	166.67	133.34	83.34	66.67	55.56	41.67	33.34
Programming Current Range	A	0~179.17	0~143.34	0~89.59	0~71.67	0~59.73	0~44.80	0~35.84
Line regulation (Note.2)	--	±0.2%						
Load regulation	--	±0.2%						
Protective &Alarm Functions								
Input Over-voltage protection	--	AC input over 275VAC shutdown, auto recovery below 260VAC; Reset by AC input or by EN Singal or by communication port.						
Input under-voltage protection	--	AC input under 85VAC shutdown, auto recovery above 90VAC						
AC fail Alarm	--	AC input voltage below 50V for 50ms						
Output Over-voltage protection	--	Shut down, Reset by AC input or by EN Singal or by communication port.						
Over temperature Alarm(OTA)	°C	Ambient temperature over 53°C; auto-recovery under 48°C						
Over temperature protection(OTP)	°C	Heat-sink temperature over 95°C,shut down and auto-recovery under 75°C						
Over current protection(OCP)	--	Constant Current Limit						
Short circuit protection(SCP)	--	shut down and auto-recovery after the short-circuit removed						
Note: 1.Ripple & noise are measured at 20MHz of bandwidth by using 12" twisted pair-wire terminated with a 0.1uF & 47uF parallel capacitor 2.At 85~132Vac or 170~265VAC, constant load. 3.From No-Load to Full-Load, constant input voltage. Measured at the sensing point in Remote Sense.								
Function								
Local Remote control	--	By electrical Voltage: 5V/12V or dry contact						
DC-OK signal	--	Open Dragin singal, sink current ≤20mA, max drain voltage 40V						
Parallel operation	--	Possible, up to 16 units with single wire current balance connection.						
Series operation	--	Possible						
Auxiliary Power	--	Selectable +5V/2A or +12V/0.83A auxiliary output						
IOA	--	High speed I/O port (digital signal input/output)						
IOB	--	Low speed I/O port (analog singal input/output)						
Temperature measurement accuracy	°C	1						
Temperature display resolution	°C	0.1						
Note: The Constant Current programming, readback and monitoring accuracy do not include the warm-up and Load regulation thermal drift.								
Input Specifications								
AC Input (Note.1)	Vac	90~264,Normal input 115VRMS/230VRMS						
DC Input	Vdc	127~370						
Input freq	HZ	47~63HZ,50/60HZ Typ 360~800,Contact factory for 400Hz application						
Input Current	--	230V/14A; 115V/18A						
Input Fuse	A	25,Each line fused 25A Slow acting						
Inrush Current	A	25A,115VAC; 50A,230VAC; 25°C cold start						

PIN Definition

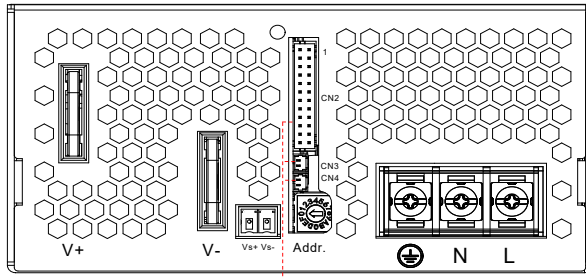

Pin	Function
L	AC Input L
N	AC Input N
⊕	AC Input FG
V+	DC Output (+)
V-	DC Output (-)
Addr	Address code



CN	Pin	Function	Description	Pin	Function	Description
CN2	2	POK	Power OK	1	VSET	Aux output setting 5V/12V
	4	GND	Ground	3	AUX	Auxiliary output positive
	6	GND	Ground	5	AUX	Auxiliary output positive
	8	EN+	Inhibit ON/OFF (+)	7	AUX	Auxiliary output positive
	10	GND	Ground	9	EN-	Inhibit ON/OFF (-)
	12	GND	Ground	11	ACI	I Program
	14	GND	Ground	13	VCI	V Program
	16	SCL	Serial Clock Line	15	SDA	Serial Data Line
	18	IOB	Low speed I/O port	17	IOA	High speed I/O port
	20	CAN-L	Controller Area Network-L	19	CAN-H	Controller Area Network-H
	22	GNDI	Isolation 5V Ground	21	+5VC	Isolation 5V positive
	24	485_B-	RS485 B-	23	485_A+	RS485_A+
Signal Connector		JST PHDR-24VS or equivalent; JST SPHD-002T-P0.5 or equivalent				
CN3/CN4	1	PAR	Parallel operation current share			
	2	GND	Ground			
Signal Connector		CJT A1251H-2P or equivalent; CJT A1251-TP or equivalent				
VS +	Remote sense(+)					
VS -	Remote sense(-)					
Signal Connector		Phoenix Contact MC 1.5/ 2-ST-3.81 Order No.: 1803578 or equivalent				

Remote ON/OFF

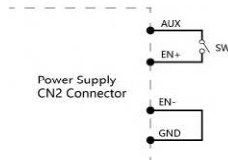

(a) Using internal 5V auxiliary source (Default Setting)

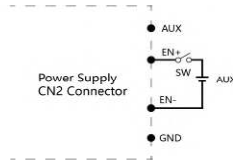

(b) Using external voltage source

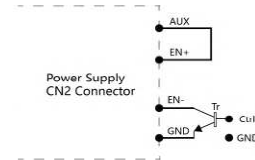

(c) ON / OFF Control by NPN transistor

Note:

GND shown in above diagram is referring to the GND of CN2, not the Grounding from main power(V-).

Output Voltage/Current Programming

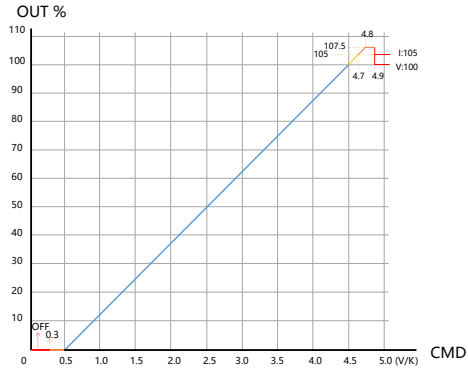

CMD VS Output Curve(0~5V)

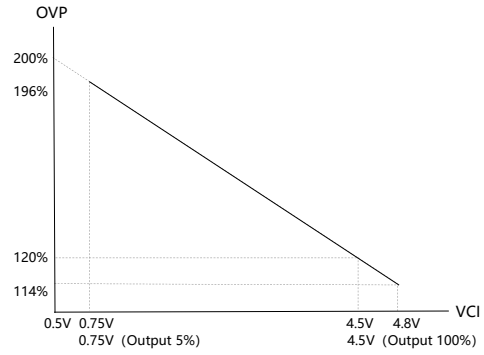

VCI VS OVP Curve

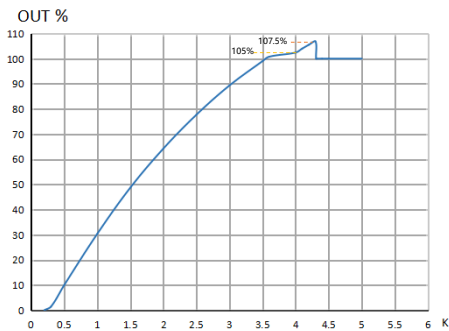

CMD VS Output Curve(0~5KΩ)

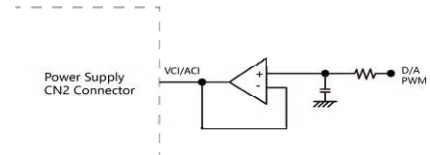
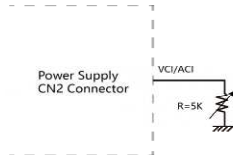
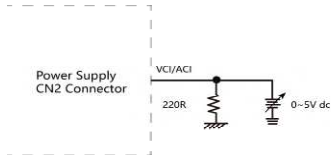

Power OK Signal & Auxiliary Power Setting

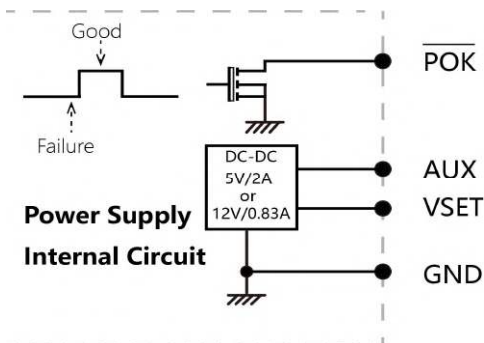

AUX and POK Signal

The grounding of "AUX" power and P.OK signals should be connected to "GND" port. If "V-" is connected as Grounding, make sure to short the GND and V- ports.

Do not exceed 5V/2A or 12V/0.83A

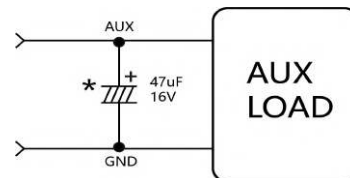

Auxiliary Power Setting

*Place an additional capacitor to have a better performance of auxiliary power operation.

Note:

GND shown in above diagram is referring to the GND of CN2, not the Grounding from main power(V-).

LED status indication

mode	Description	LED Signal	LED Slow=750ms; Fast=250ms
Local mode	Power Standby		Slow Blink (Green)
	Power OK		Solid (Green)
Remote mode	Power Standby		Slow Blink (Orange)
	Power OK		Solid (Orange)
Local/Remote mode	AC Failure		Alternating flicker (Red&Green)
	FAN Failure		
	OTA		
	AC Input Over /Under Voltage Protection		Fast Blink (Red)
	BUS Over Voltage Protection (OVP)		Intermittent Blink (Red)
	Over Load Protection (OLP)		Interlace Blink (Red)
	Over Temperature Protection (OTP)		Slow Blink (Red)
DC Output Over Voltage Protection (OVP)		Solid (Red)	

Mechanical Drawings

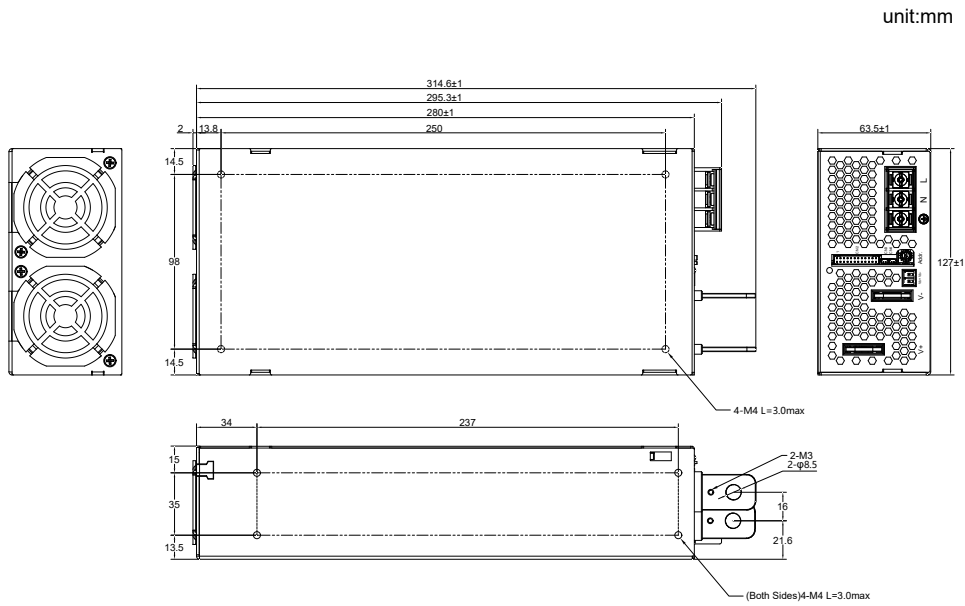

Notes:

- 1, Input: terminal block type, M4 screw torque value of 16kgf-cm using wire gauge 18-10 (13mm centers)
- 2, Output terminal block, M8 screw in 2 positions, torque 10.8 N m(110kgf cm)

Installation precautions

unit:mm

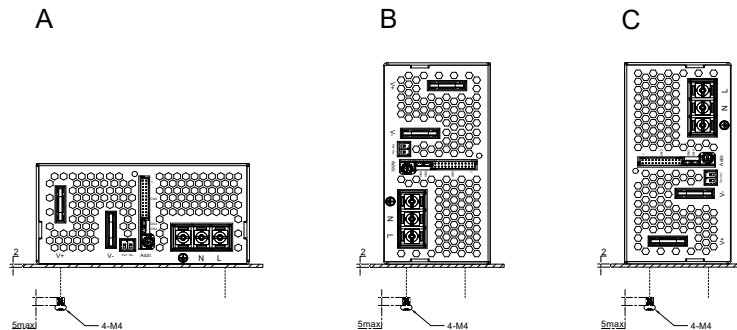

Notes:

- 1, Recommended standard mounting methods A, B, C
- 2, The Maximum allowable penetration of screw is 4mm. Incomplete threading should not be penetrated

Installation precautions

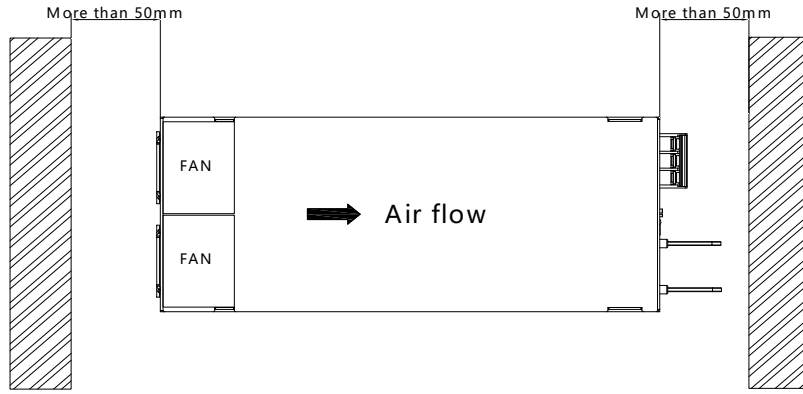

Notes:
There are ventilating holes on the front and back side panels, do not obstruct; allow 50mm at least for air flow.

Want to know more?

For sales, technical support or additional information please get in touch with our team of experts.

ADDITIONAL SERVICES

We provide an end-to-end service

From the initial consultation and sourcing unique components to supplying bespoke solutions including a full design and build process

Bespoke services

Customised and curated technology solutions across the full range of Conexa Tech Products

Sourcing

A full suite of electronics, cable and mechanical sourcing capabilities

Design & Build

Development and manufacturing services

hello@conexotech.com | +44 118 402 3430

CONEXATECH.COM